

ICC-ES Evaluation Report

ESR-3748

Reissued May 2026

Subject to renewal May 2027

This report also contains:

- City of LA Supplement
- CA Supplement
- FL Supplement

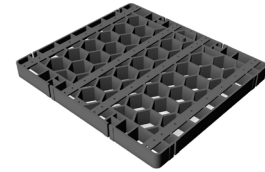

ICC-ES Evaluation Reports are not to be construed as representing aesthetics or any other attributes not specifically addressed, nor are they to be construed as an endorsement of the subject of the report or a recommendation for its use. There is no warranty by ICC Evaluation Service, LLC, express or implied, as to any finding or other matter in this report, or as to any product covered by the report.

Copyright © 2026 ICC Evaluation Service, LLC. All rights reserved.

<p>DIVISION: 06 00 00— WOOD, PLASTICS AND COMPOSITES</p> <p>Section: 06 53 00— Plastic Decking</p>	<p>REPORT HOLDER: SILCA SYSTEM, LLC, dba STONEDEKS SYSTEM</p> 	<p>EVALUATION SUBJECT: SILCA GRATE</p>	
---	---	--	---

1.0 EVALUATION SCOPE

Compliance with the following codes:

- 2021, 2018, 2015 and 2012 [International Building Code® \(IBC\)](#)
- 2021, 2018, 2015 and 2012 [International Residential Code® \(IRC\)](#)

Properties evaluated:

- Structural
- Durability
- Surface-burning characteristics

2.0 USES

The Silca Grate is used to span between horizontal wood framing members to support flooring materials for exterior decks, balconies, porches and stair treads of Type V-B (IBC) construction. For structures regulated under the IRC, the Silca Grate may be used where an engineered design is submitted in accordance with IRC Section R301.1.3.

3.0 DESCRIPTION

3.1 General:

Silca Grate is an injection molded plastic grate with a honeycomb structure, nominally 16 inches by 18¹/₄ inches by 1¹/₂ inches (406 mm x 464 mm x 38 mm). See [Figure 1](#) for actual dimensions. When used for stair treads, the grates are cut in the field to nominal dimensions of 16 inches by 11 inches (406 mm x 279 mm). The grates have holes for screws that are used to attach the panels to deck joists and stair stringers.

3.2 Durability:

Silca Grate durability has been qualified in accordance with ASTM D7032, which is referenced in 2021, 2018 and 2015 IBC Section 2612.

3.3 Material:

The Silca Grate is manufactured using injection molded PC-ABS plastic specified in the manufacturer’s quality documentation. The plastic is black in color and does not contain any wood, cellulosic or biodegradable materials.

3.4 Surface-burning Characteristics:

When tested in accordance with ASTM E84, Silca Grate has a flame-spread index of no greater than 200, as required by 2021, 2018 and 2015 IBC Section 2612.3.

4.0 DESIGN AND INSTALLATION

4.1 General:

Installation of the Silca Grate panel and stair tread must comply with this report, the manufacturer's published installation instructions and the applicable code. The manufacturer's published installation instructions must be available on the jobsite at all times during installation.

4.2 Design:

The Silca Grate, when used to span between floor framing members, has an allowable capacity (span rating) as shown in [Table 1](#).

The Silca Grate, when used as a stair tread, is capable of resisting the code-prescribed concentrated load of 300 pounds (1.34 kN) when installed as described in [Table 2](#).

4.3 Installation:

The Silca Grates, when used to span between floor framing or stair treads, are installed on 2 x wood members spaced according to [Tables 1](#) or [2](#) using #9, corrosion resistant wood screws, 3 inches long (76 mm), located in each of the screw holes of the grate.

Floor coverings (not supplied by Silca System) are installed over the panels. Floor coverings may consist of natural stone or manufactured pavers.

5.0 CONDITIONS OF USE:

The Silca Grate described in this report complies with, or is a suitable alternative to what is specified in, those codes listed in Section 1.0 of this report, subject to the following conditions:

- 5.1 Installation must comply with this report, the manufacturer's published instructions and the applicable code. When there is a conflict between this report and the manufacturer's published installation instructions, this report governs.
- 5.2 This product is limited to exterior deck, balconies, porches and stair treads of Type V-B (IBC) construction and structures constructed in accordance with the IRC.
- 5.3 Only those fasteners described in this report have been evaluated for the installation of the Silca Grate panels. The compatibility of the fasteners with the supporting construction, including chemically treated wood, is outside the scope of this report.
- 5.4 Silca Grate panels must be directly fastened to the supporting construction. Where required, engineering calculations and construction documents consistent with this report must be submitted to the code official for approval. The calculations must verify that the supporting construction complies with the applicable building code requirements and is adequate to resist the loads imparted upon it from the products and systems described in this report. The documents must contain details of the attachment of the panels to the supporting structure consistent with the requirements of this report. The documents must be prepared by a registered design professional where required by the statutes of the jurisdiction in which the project is to be constructed.
- 5.5 Anchoring of the flooring materials over the Silca Grate is outside the scope of this report. The determination of wind uplift and other loads applicable to the flooring materials must be determined by a design professional.
- 5.6 A solid floor covering must be installed over the Silca Grate.
- 5.7 The Silca Grate is manufactured under a quality control program with inspections by ICC-ES.

6.0 EVIDENCE SUBMITTED

- 6.1 Report of testing in accordance with the following ASTM D7032 provisions: Section 4.4 for flexure resistance, Section 4.5 for temperature effects, Section 4.7 for freeze thaw resistance, Section 5.4 for creep-recovery, and Section 5.5 for mechanical fastener resistance.
- 6.2 Report of testing in accordance with Section 4.1.2 (Ultraviolet Light Exposure) of the [Acceptance Criteria for Water-resistive Barriers \(AC38\)](#) dated August 2016 (editorially revised July 2021).

- 6.3 Report of testing in accordance with ASTM D7031 Section 5.10.2 for duration of load (creep-rupture resistance).
- 6.4 Report of testing in accordance with ASTM E84 for surface burning characteristics (flame spread index).
- 6.5 Quality documentation in accordance with the [ICC-ES Acceptance Criteria for Quality Documentation \(AC10\)](#), dated January 2019.

7.0 IDENTIFICATION

- 7.1 The Silca Grate must be identified with the company name (StoneDeks System), product name (Silca Grate), the allowable span and allowable load for the panel, the allowable span for the stair tread, and the evaluation report number (ESR-3748).
- 7.2 The report holder’s contact information is the following:

SILCA SYSTEM, LLC, dba STONEDEKS SYSTEM
14600 COMMERCE STREET NE
ALLIANCE, OHIO 44601
(330) 821-1585
www.stonedeks.com

TABLE 1—DECK PANEL SPAN RATINGS

PRODUCT NAME	MAXIMUM SPAN ¹ (inches)	ALLOWABLE LIVE LOAD ^{2,3} (lb/ft ²)
SilcaGrate	16	100

For **SI**: 1 inch = 25.4 mm, 1 = 47.9 Pa

¹Maximum span is measured center-to-center of the supporting framing members.

²Based on a dead load allowance of 30 lb/ft² to account for the weight of the flooring material and a deflection limit of L/180.

³Maximum allowable capacity includes adjustment for durability, described in Section 3.2. No increases are permitted.

TABLE 2—MAXIMUM STAIR TREAD SPANS

PRODUCT NAME	MAXIMUM SPAN ^{1,2} (inches)
Silca Grate Stair tread	Supported on all four sides, 16 X 8 ³ / ₄ , See Note 3

For **SI**: 1 inch = 25.4 mm

¹Maximum span is measured center-to-center of the supporting construction.

²Maximum span is based on a concentrated load of 300 lbf (1.34 kN).

³The Silca Grate, which is cut to 16 inches wide by 11 inches long, must bear a minimum of ³/₄ inch on each supporting stringer and must fully bear on the blocking members.

SILCA GRATE DRAWING

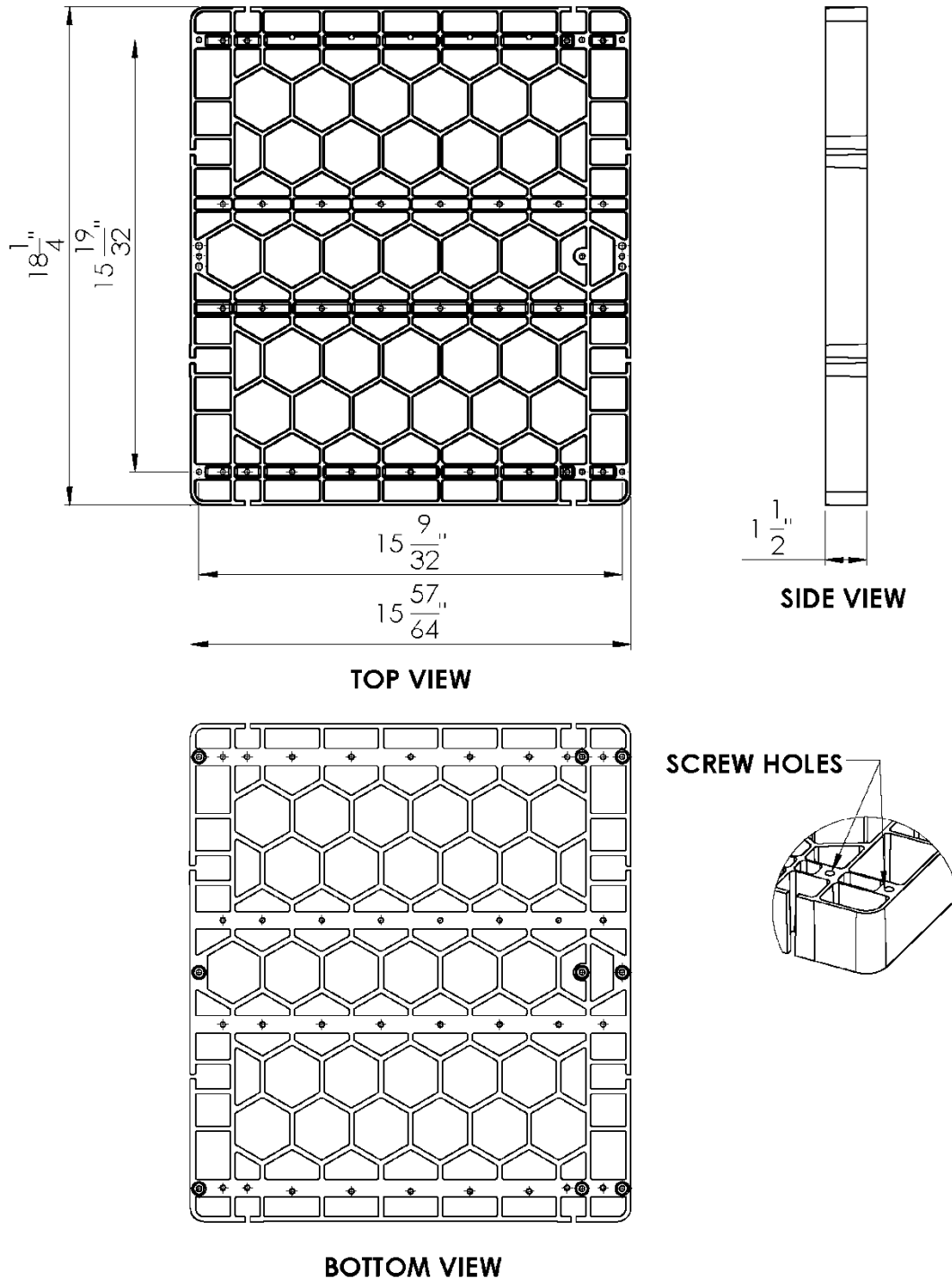

FIGURE 1—SILCA GRATE
(SI Units; 1 inch = 25.4 mm)

DIVISION: 06 00 00—WOOD, PLASTICS AND COMPOSITES
Section: 06 53 00—Plastic Decking

REPORT HOLDER:

SILCA SYSTEM, LLC, dba STONEDEKS SYSTEM

EVALUATION SUBJECT:

SILCA GRATE

1.0 REPORT PURPOSE AND SCOPE**Purpose:**

The purpose of this evaluation report supplement is to indicate that Silca Grate, described in ICC-ES evaluation report [ESR-3748](#), has also been evaluated for compliance with the codes noted below as adopted by the Los Angeles Department of Building and Safety (LADBS).

Applicable code editions:

- 2020 *City of Los Angeles Building Code* ([LABC](#))
- 2020 *City of Los Angeles Residential Code* ([LARC](#))

2.0 CONCLUSIONS

The Silca Grate, described in Sections 2.0 through 7.0 of the evaluation report [ESR-3748](#), complies with the LABC Chapters 14 and 26, and the LARC, and is subject to the conditions of use described in this supplement.

3.0 CONDITIONS OF USE

The Silca Grate described in this evaluation report supplement must comply with all of the following conditions:

- All applicable sections in the evaluation report [ESR-3748](#).
- The design, installation, conditions of use and identification of the Silca Grate are in accordance with the 2018 *International Building Code*® (IBC) provisions noted in the evaluation report [ESR-3748](#).
- The design and installation are in accordance with additional requirements of LABC Chapter 26.
- Under the LARC, an engineered design in accordance with LARC Section R301.1.3 must be submitted.

This supplement expires concurrently with the evaluation report reissued May 2026.

DIVISION: 06 00 00—WOOD, PLASTICS AND COMPOSITES
Section: 06 53 00—Plastic Decking

REPORT HOLDER:

SILCA SYSTEM, LLC, dba STONEDEKS SYSTEM

EVALUATION SUBJECT:

SILCA GRATE

1.0 REPORT PURPOSE AND SCOPE**Purpose:**

The purpose of this evaluation report supplement is to indicate that the Silca Grate, described in ICC-ES evaluation report [ESR-3748](#), has also been evaluated for compliance with the codes noted below.

Applicable code editions:

- 2019 *California Building Code* (CBC)

For evaluation of applicable chapters adopted by the California Office of Statewide Health Planning and Development (OSHPD) AKA: California Department of Health Care Access and Information (HCAI) and the Division of State Architect (DSA), see Sections 2.1.1 and 2.1.2 below.

- 2019 *California Residential Code* (CRC)

2.0 CONCLUSIONS**2.1 CBC:**

The Silca Grate, described in Sections 2.0 through 7.0 of the evaluation report [ESR-3748](#), complies with CBC Chapters 14 and 26, provided the design and installation are in accordance with the 2018 *International Building Code*® (IBC) provisions noted in the evaluation report and the additional requirements of CBC Chapter 26, as applicable.

The product has not been evaluated under Chapter 7A for use in the exterior design and construction of new buildings located in a Fire Hazard Severity Zone within State Responsibility Areas or any Wildland–Urban Interface Fire Area.

2.1.1 OSHPD: The applicable OSHPD Sections and Chapters of the CBC are beyond the scope of this supplement.

2.1.2 DSA: The applicable DSA Sections and Chapters of the CBC are beyond the scope of this supplement.

2.2 CRC:

The Silca Grate, described in Sections 2.0 through 7.0 of the evaluation report [ESR-3748](#), complies with CRC Chapter 3, provided the design and installation are in accordance with the 2018 *International Residential Code*® (IRC) provisions noted in the evaluation report and the additional requirements of CRC Chapter 3.

The product has not been evaluated under CRC Section R337 for use in the exterior design and construction of new buildings located in a Fire Hazard Severity Zone within State Responsibility Areas or any Wildland–Urban Interface Fire Area.

The product in this supplement has not been evaluated for compliance with the *International Wildland–Urban Interface Code*®.

This supplement expires concurrently with the evaluation report, reissued May 2026.

DIVISION: 06 00 00—WOOD, PLASTICS AND COMPOSITES
Section: 06 53 00—Plastic Decking

REPORT HOLDER:

SILCA SYSTEM, LLC, dba STONEDEKS SYSTEM

EVALUATION SUBJECT:

SILCA GRATE

1.0 REPORT PURPOSE AND SCOPE**Purpose:**

The purpose of this evaluation report supplement is to indicate that the Silca Grate, described in ICC-ES evaluation report [ESR-3748](#), has also been evaluated for compliance with the codes noted below.

Applicable code editions:

- 2020 Florida Building Code—Building
- 2020 Florida Building Code—Residential

2.0 CONCLUSIONS

The Silca Grate, described in ICC-ES evaluation report [ESR-3748](#), complies with the *Florida Building Code—Building* and the *Florida Building Code—Residential*. The design requirements must be determined in accordance with the *Florida Building Code—Building* or the *Florida Building Code—Residential*, as applicable. The installation requirements noted in ICC-ES evaluation report [ESR-3748](#) for the 2018 *International Building Code*® meet the requirements of the *Florida Building Code—Building* and the *Florida Building Code—Residential*.

Use of the Silca Grate for compliance with the High-Velocity Hurricane Zone provisions of the *Florida Building Code-Building* or the *Florida Building Code-Residential* has not been evaluated, and is outside the scope of this supplemental report.

For products falling under Florida Rule 61G20-3, verification that the report holder's quality assurance program is audited by a quality assurance entity approved by the Florida Building Commission for the type of inspections being conducted is the responsibility of an approved validation entity (or the code official when the report holder does not possess an approval by the Commission).

This supplement expires concurrently with the evaluation report reissued May 2026.