

DIVISION: 06 00 00 – WOOD, PLASTICS AND COMPOSITES
Section: 06 53 00 - Plastic Decking

REPORT HOLDER:
StoneDeks System
14600 Commerce Street N.E.
Alliance, OH 44601
330-821-1585
<https://stonedeks.com/>

REPORT SUBJECT:
SilcaGrate™

1.0 SCOPE OF EVALUATION

1.1 This Research Report addresses compliance with the following Codes:

- 2018 and 2015 *International Building Code*® (IBC)
- 2018 and 2015 *International Residential Code*® (IRC)
- 2017 *Florida Building Code* (excluding HVHZ)
- 2019 *California Building Code*

NOTE: This report references 2018 IBC sections with [2015] IBC sections shown in brackets where they differ.

1.2 SilcaGrate™ has been evaluated for the following properties:

- Structural performance
- Durability
- Surface Burning
- Decay Resistance
- Termite Resistance

1.3 SilcaGrate™ has been evaluated for the following uses (see Table 1):

- Exterior deck subfloor on exterior decks, balconies, porches walkways and stair tread.
- Use in One- and Two-Family Dwellings regulated by the IRC and other construction types regulated by the IBC in accordance with IBC Section 705.2.3 *Combustible projections* [1406.3], where fire-resistance rated floor construction is not required for the deck or balcony.

2.0 STATEMENT OF COMPLIANCE

SilcaGrate™ complies with the Codes listed in Section 1.1, for the properties stated in Section 1.2 and uses stated in Section 1.3, when installed as described in this report, including the Conditions of Use stated in Section 6.

3.0 DESCRIPTION

3.1 SilcaGrate™ is a weather-resistant plastic grate designed for installation on wood deck framing to support finished deck surface materials such as cut stone or precast pavers.

3.2 SilcaGrate™ is an injection molded honeycomb grate nominally 16 inches by 18 inches and 1.5 inches tall. Each grate has a series of holes for fastening to deck framing and stringers. For stair tread applications, the SilcaGrate™ is field cut from one edge down to 16 inches by 11 inches.

4.0 PERFORMANCE CHARACTERISTICS

4.1 SilcaGrate™ subfloor panels are rated for a Span/Load Rating of 16/100 (16.0 in. Span and 100 psf Live Load) installed on support framing spaced 16 inches on center.

4.2 When used to support stair treads, SilcaGrate™ are rated for the code-prescribed concentrated load equal to 300 lbs. when supported on all four sides.

4.3 Structural performance has been demonstrated for a temperature range from -20 °F to 125 °F.

4.4 SilcaGrate™ panels have a flame spread index of less than 200 when tested in accordance with ASTM E84.

4.5 SilcaGrate™ may be used where the code requires preservative treated or naturally durable wood for resistance to weathering effect, attack from termites, and fungus decay.



5.0 INSTALLATION

5.1 General:

SilcaGrate™ subfloor panels must be installed in accordance with the manufacturer's published installation instructions, the applicable Code, and this Research Report. A copy of the manufacturer's instructions must be available on the jobsite during installation.

5.2 Dead load of finished deck coverings placed on the installed SilcaGrate™ subfloor panels shall not exceed 30 psf. The deck covering is not within the scope of this evaluation.

5.3 SilcaGrate™ subfloor panels shall be fastened to wood deck framing spaced 16 inches with #9 x 3 inch corrosion resistance screws located in the screw holes at each corner of the grate.

6.0 CONDITIONS OF USE

6.1 Installation must comply with this Research Report, the manufacturer's published installation instructions, and the applicable Code. In the event of a conflict, this report governs.

6.2 Compatibility fasteners with the supporting construction materials including chemically treated wood are outside the scope of this evaluation and subject to approval by the code official.

6.3 Installation of deck coverings and wind uplift resistance is outside the scope of this report. Evaluation of wind loads and uplift resistance shall be made by a qualified engineer to the satisfaction of local code officials or other authorities having jurisdiction.

6.4 Where required by the building official, engineering calculations and details shall be provided. The documentation shall verify that the installation complies with this report and the applicable building code for the type of framing and condition of the supporting construction.

6.5 SilcaGrate™ is manufactured under a quality control program with inspections by Intertek Testing Services NA, Inc.

7.0 SUPPORTING EVIDENCE

7.1 Manufacturer's drawings and installation instructions.

7.2 Reports of testing in accordance with ICC-ES AC174, *Acceptance Criteria for Deck Board Span Ratings and Guardrail Systems (Guards and Handrails)*, dated January 2012, editorially revised Dec. 2014.

7.3 Documentation of an Intertek approved quality control system for the manufacturing of products recognized in this report

8.0 IDENTIFICATION

SilcaGrate™ subfloor panels are identified with the manufacturer's name (StoneDeks Systems), address and telephone number, the product name (SilcaGrate™), the Intertek Mark and the Code Compliance Research Report number (CCRR-0366) as shown below,



9.0 OTHER CODES

9.1 2017 FLORIDA BUILDING CODE. SilcaGrate™ has been evaluated for compliance with the 2017 Florida Building Code – sixth edition excluding High Velocity Hurricane Zone (HVHZ).

Intertek is an approved evaluation entity and quality assurance entity pursuant to Florida Statute 553.842 – *Product Evaluation and Approval*.

9.2 2019 CALIFORNIA BUILDING CODE. SilcaGrate™ has been evaluated for compliance with the 2019 California Building Code.





10.0 CODE COMPLIANCE RESEARCH REPORT USE

10.1 Approval of building products and/or materials can only be granted by a building official having legal authority in the specific jurisdiction where approval is sought.

10.2 Code Compliance Research Reports shall not be used in any manner that implies an endorsement of the product by Intertek.

10.3 Reference to the <https://bpdirectory.intertek.com> is recommended to ascertain the current version and status of this report.

Table 1 – Span / Load Ratings

Span / Load Ratings ⁽¹⁾		Maximum Stair Tread Span ⁽²⁾	Fastener
Live Load	Max. Dead Load		
16" / 100 psf	30 psf	16" Span	Four (4) #9 x 3 inch corrosion resistant screws

- ⁽¹⁾ Span/Load rating is the maximum span in inches and the maximum allowable live load in pounds per square feet (psf). The maximum allowable loads indicated include applicable end use factors. No additional adjustments should be taken.
- ⁽²⁾ SilcaGrate™ for stair tread applications is field cut from one edge to 16" by 11" and Span/Load is based on continuous support along all four sides.



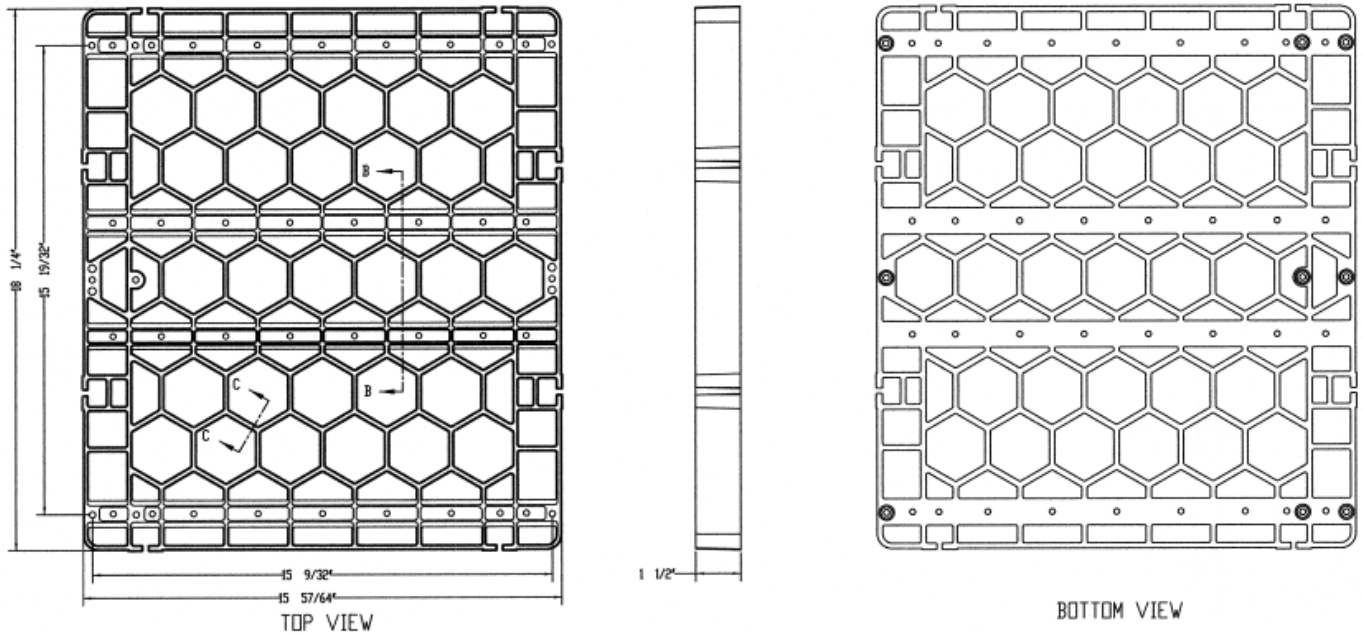

Figure 1 - SilcaGrate™

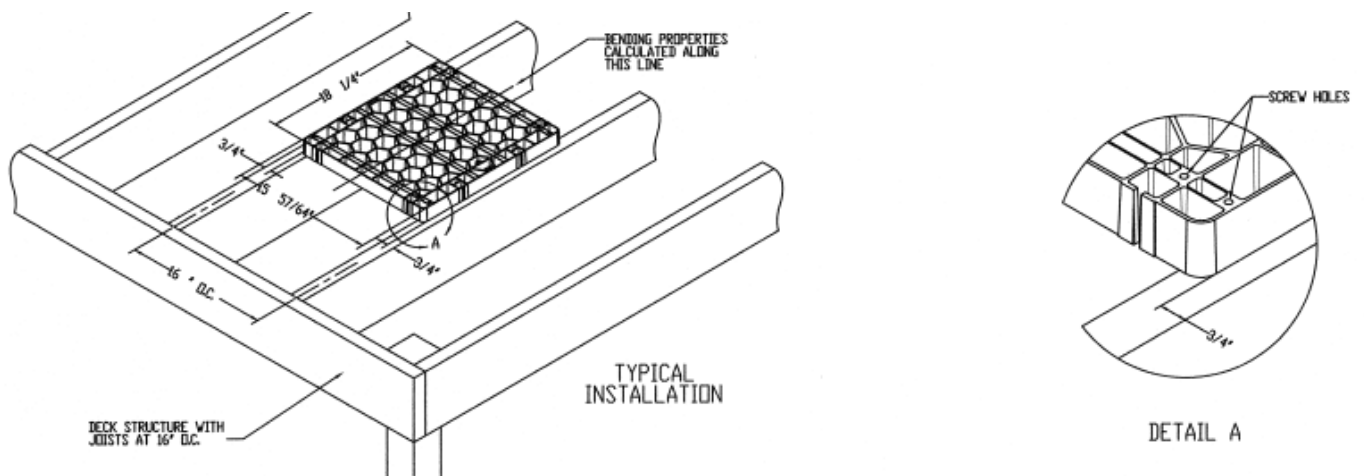

Figure 2 – Typical Installation

